



Virtus-E Multipoint Lock Installation Instructions

(for use with Schlage Artus and Resolute Smart Locks)

Contents

1. Mortise lock
2. Vertical rod kit
3. Schlage electronic lock

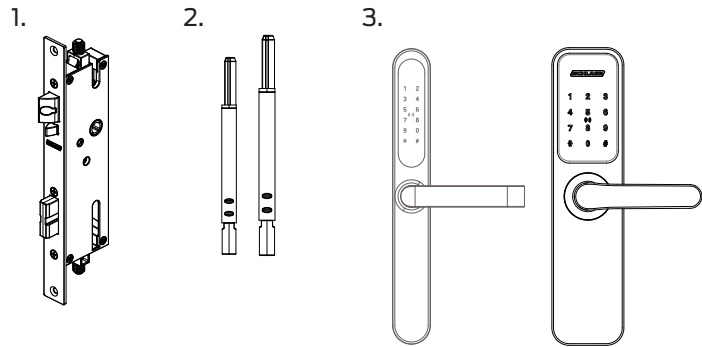

Read all steps before attempting installation.
Routing instructions and lock dimensions on following pages.

Prepare the Latch

- A. Check latch to determine if handing is correct.
- B. To re-hand the latch, turn the latch head screw counter-clockwise with a screwdriver (by hand) until the latch is proud of the forehand.
- C. Rotate the latch head 180° and re-tighten the screw fixing.
- D. To increase the latch projection turn the latch screw counter-clockwise.
- E. Latch projection can be increased by a maximum of 2mm from the original position.

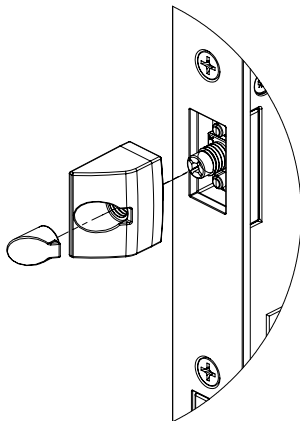

Shootbolt Assembly

(Required for Multipoint Locking Only)

- A. Cut the shoot bolts to the required length as per instructions below:
- B. Measure the distances as shown.
- C. Use the formula below and cut the lengths (lengths include threaded end piece).
$$\text{Top Rod (TR)} = \text{Panel Height (PH)} - \text{Handle Centre (HC)} - 97\text{mm}$$
$$\text{Bottom Rod (BR)} = \text{Handle Centre (HC)} - 152.4\text{mm}$$

(Using this formula will result in the shoot bolts being flush with the top of the door panel).
- D. Insert D-bolt into top/bottom of shoot bolt vertical rod.
- E. Crimp D-bolt to retain and hold.
- F. Insert rods from the top and bottom of the stile and screw into the lock.
- G. Retain D-bolts in stile to prevent rotation but allow throw.

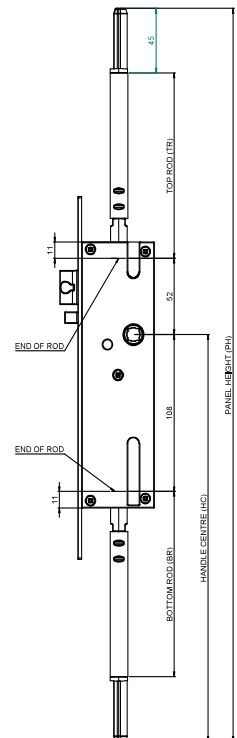

Allegion New Zealand

Freephone 0800 477 869
Email nzinfo@allegion.com
www.allegion.co.nz

PDSC0104
© 2026 Allegion

